



Qv2 AC Line Harmonizer

The QRT Qv2 is the latest addition to the QRT range, a family of modular, non-intrusive products that deliver an innovative, measurable and sonically effective solution to the issues of AC quality and audio/video performance. In keeping with that approach, the Qv2's benefits are complementary, adding to and building on the proven musical advantages already delivered by the established, multi-award winning Qb distribution units and Qx field generators. Only this time the Qv2 applies QRT technology directly to the AC line, introducing a carefully calculated range of harmonic frequencies to your system's AC supply, clocked from the line frequency itself. Simply plug it into a spare socket on your distribution block (or the same power line that your system's connected to) and you'll hear your music or view your movies with a new sense of space and immediacy, clarity and presence. It really is that simple.

Equally effective on audio or AV systems, you can use Qv2 as a first step towards better performance, or as an upgrade on an existing Qb or Qx installation. Either way you'll hear an obvious improvement in the natural flow and harmonic warmth, the sense of life and expression from your music and movies. That's quite a claim for a unit that's so compact as well as so affordable. On that basis, what (you might well wonder) could be better than a Qv2? That's just as simple: Two Qv2s! Just like the Qx2 and Qx4, the sonic impact of the Qv2 is cumulative, meaning that two used in



- Improves sound and picture quality.
- Increases the depth and realism of the musical performance.
- Lower perceived background noise.
- Deeper, more dimensional and more vibrant picture on AV systems.

tandem sounds more than twice as good as a single unit on its own, while four... Well, perhaps we'd better leave that to your imagination, but you get the picture.

The QRT Qv2 – one upgrade that's literally plug and play!

The Qv2 is housed in a high-quality, mechanically tuned, carbon-fiber body and equipped with either a US (NEMA) or Eu (Schuko) connection. It is simply inserted into a spare socket adjacent to the system and on the same AC line (a spare socket on your QBASE is ideal). It is compatible with voltages from 110V to 240V, can be used with an adaptor if required and carries a two-year warranty.



Instructions included and also available from:
www.nordost.com

Using The Qv2

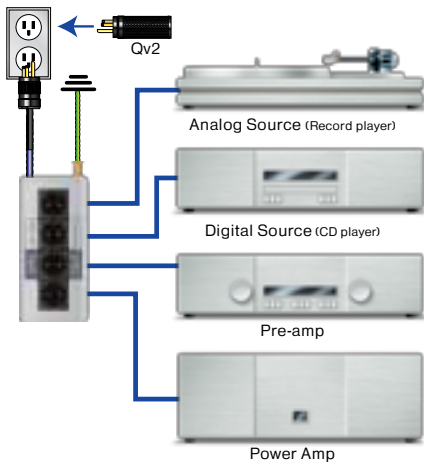

A single Qv2 in a basic two-channel system

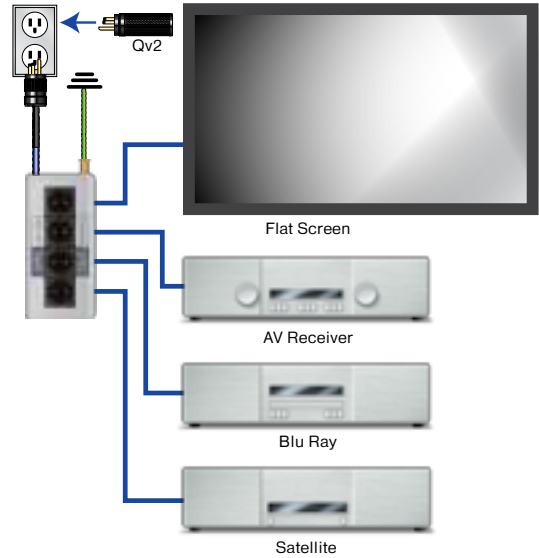

A single Qv2 in a basic AV system

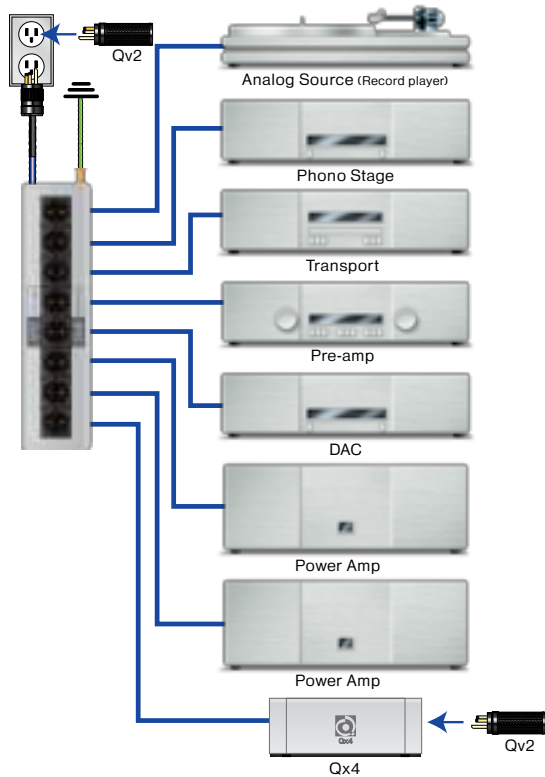

A pair of Qv2s in addition to a Qx4 in a complex two-channel system

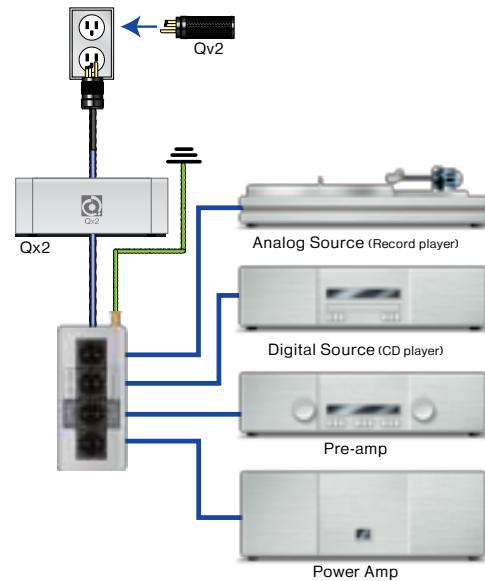

A Qv2 used with a Qx4 in a simple two-channel system

QRT™
 Distributed worldwide by
NORDOST